

## “THE PRO-WRAPPER”

- A: Head stock track assembly (1pc). Includes: One 2’ 8” bass section with power platform, two motors, self centering chuck and chuck support, speed control, double drive pulley, three position switch, large “O” ring drive belt (plus one spare), power cord and foot control.
- B: Additional 2’8” aluminum base sections (2pcs.)
- C: Stainless steel connecting bars (4 pcs.) with mounting screws (16 pcs.) and 8mm nuts (16 pcs.)
- D: Adjustable upright supports (3 pcs.)
- E: Thread carrier assembly (1 pc.). Includes carrier platform with three ball bearing rollers, thread tension device, two ceramic thread guides, four spool post, magnet, and a wood spacer for four ounce spools.

### ASSEMBLY AND SET-UP OF “THE PRO-WRAPPER”

Locate the one base section with holes drilled in both ends. This is your center section. Note that optional/base sections will also have holes drilled in both ends., and should be used as inside sections. Always use your current end section in the end position when additional sections are purchased.

Attach sections using connecting bars and screws, as shown in Figure 1 (the holes in the bards are threaded so you can assemble the base using only a screwdriver). The 8mm nuts are supplied to further assure that the sections do not shift. This would upset the tracking ability of the thread carrier at each of the joints.

Before fully tightening the screws and nuts, install the thread carrier as shown in Figure 2 and check its tracking ability over each joint. A slight resistance is acceptable, but if the wheels hang up, try gently shifting the sections into position. Once this is accomplished, tighten all screws. Complete the connections by fully tightening the 8mm nuts. HINT: A little paraffin applied to the track surfaces will further smooth the carrier’s tracking ability over these joints. Track surfaces should be cleaned regularly for best operation and paraffin re-applied if utilized.

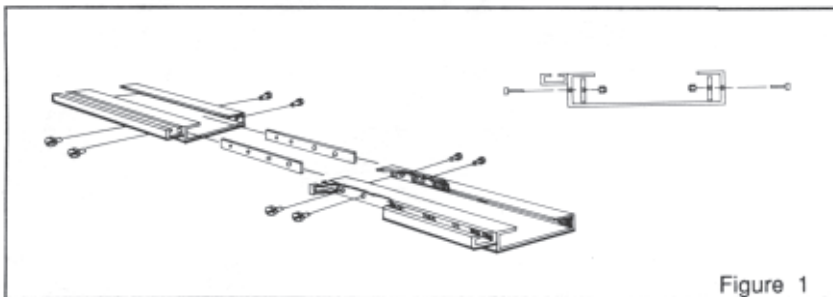

Figure 1

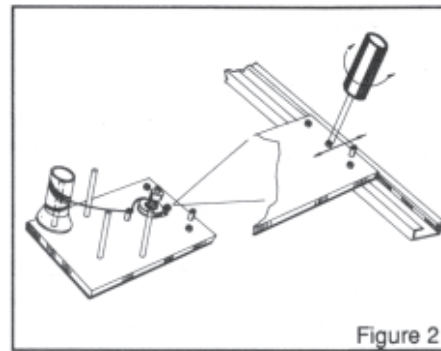

Figure 2

If in the future you feel it is necessary to fine tune the tracking of your thread carrier, it can be accomplished by loosening the center wheel. Since the center wheel is mounted in an oval hole, you can position it forward or backwards to adjust the carrier within its track. See Figure 2.

You may store up to four spools of thread on the carrier, one on each of the four post. A wooden spool spacer is provided to allow the use of the old 4 oz. spools of thread the many rod builders still utilize.

The dark button to the left of the thread tension device is a magnet for holding a razor blade. In addition to its holding ability, the magnet provides a habitual location for storing the blade; in this way it will always be close at hand.

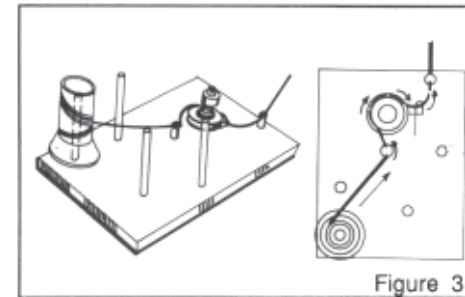

Figure 3

The threading procedure for the carrier is quite simple. First, with the carrier in its track between you and the machine, hook your thread into the ceramic guide in the center of the platform. Next, bring the thread around the left side of the tensioner and between the two chrome plates until you can catch the wire take-up hook. See Figure 3. Finally, run the thread from the take-up hook through the remaining ceramic guide. Threading in this manner allows you to increase or decrease the tension by simply adjusting the thrum screw on the top of the tensioner.

**CAUTION:** Start with the lightest possible setting and increase as needed. If you start with a heavy setting the thread may break. Also, using more than two threads at one time in the tensioner is not recommended. More than two does not allow uniform tension on all threads which can cause problems in the wrapping.

### THREAD CARRIER TENSIONER

The thread carrier assembly will permit hands free tracking with most blanks when the wheels are properly adjusted. We do recommend you monitor this closely to prevent over-wrapping. Since the carrier is pre-adjusted at the factory. It should not be necessary to make adjustments prior to your initial use of the machine.

### SET-UP AND OPERATION FOR THE TCHUCK

The wrapper is equipped with a self-centering three jaw chuck mounted on a ball bearing main shaft. With the jaws fully opened, the chuck is capable of holding blanks to a maximum of 1.5 inches in outside diameter.

The operation of the chuck is also quite simple. The first step is to loosen the wing nut on the back of the chuck. Next, open the jaws of the chuck by turning the two chuck plates in opposite directions at the same time. When the rod butt is inserted, close the jaws against the rod by reversing this operation. You must then lock the jaws in place by tightening the wing nut, firmly against the backing plate. See Figure 4.

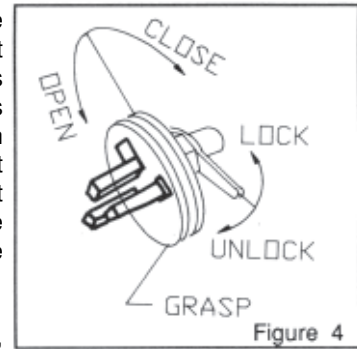

Figure 4

If the handle of your rod has a reverse taper, it may try to work out of the chuck while turning. To correct this, first be certain that the rod has aligned itself to the center of the chuck. You should then try to shim the butt of the rod with just enough masking tape to eliminate the taper.

### UPRIGHT SUPPORTS

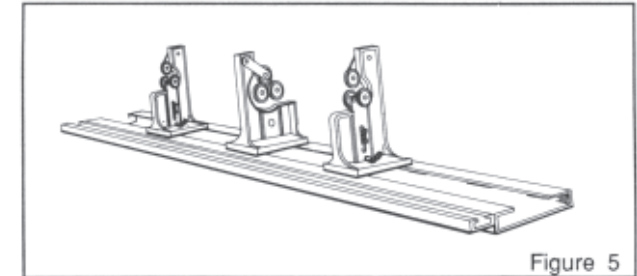

Figure 5

The three upright supports that come with the Pro-Wrapper work together with the chuck in holding the blank for thread wrapping and grip shaping. They can be positional anywhere along the aluminum base by simply loosening the lower wing nut. Loosening this nut also enables you to turn the middle support 180 degrees to oppose the other two supports as shown in Figure 5. This will provide more positive holding of large diameter blanks.

For balanced operation, it is necessary to adjust the supports relative to the chuck height each time you change to a blank with a different diameter. Do this as follows:

- A. After you flip up the spring loaded roller on each of the uprights, lay the blank on the double roller assemblies, butt end towards the chuck. Close the spring rollers on top of the blank.
- B. Adjust the double rollers up or down to the level of the chuck by loosening the wing nut on each support.
- C. Tighten the chuck as previously explained. Test your set-up by operating the wrapping motor at a moderate speed ( wrapping motor instructions follow). If necessary, repeat step B.

## CONTROLLING THE MOTOR ASSEMBLY

There are two motors. The smaller motor is for coasting and drying. The larger sewing machine type motor is for shaping and power wrapping.

### To Power Wrap

- A. The drive belt must be connected from the small pulley on the wrapping motor shaft to the large diameter groove of the double pulley which drives the chuck. See Figure 6. To remove the belt from the machine or to install a new belt, press down gently on the wrapping motor. This will allow clearance for the belt by enlarging the gap between the motor mount and drive pulley. **DO NOT FORCE THE BELT THROUGH THIS GAP.** Even a slight abrasion will decrease its life or result in immediate belt failure.
- B. Put the three way switch in the "WRAP" position.
- C. Adjust the speed control dial to 3 or 4 (this allows for the fine slow speed control while using the foot pedal).

To turn cork grips, follow the above instructions but turn the speed control dial to 10. This will give you maximum speed while operating the foot control.

### To Coat and Dry

- A. Move the drive belt to the pulley on the finish/dry motor and to the small diameter groove on the double drive pulley. See Figure 7.
- B. Move the three way switch to the "DRY" position.

**NOTE:** This smaller motor will operate in either direction. To reverse its direction, turn the switch to "OFF" and then to "DRY" again.

**TIP FOR FANCY WRAPS:** The ball bearing head stock allows you to hand turn the Pro-Wrapper for your complicated fancy wraps or when wrapping delicate tip sections. The inside face of the drive pulley is marked at 45 degree increments to help in setting up fancy wraps and keeping guides in alignment.

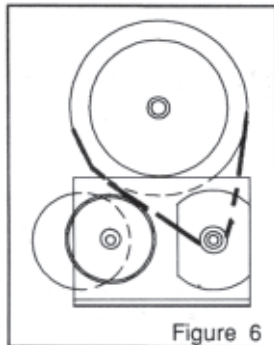

Figure 6

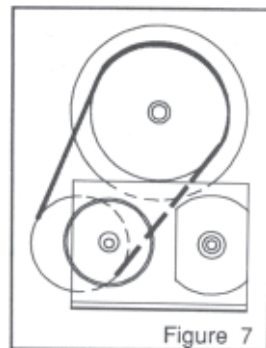

Figure 7

## PARTS

- Aluminum Base w/Metal Slates & screws
- Cermic Line Guide
- Chuck Support W/Pulley
- Chuck W/Wrench
- Drying Motor
- Foot Pedal
- Large O Ring
- O Ring of Rod Stand
- Rod Stand W/All Components
- Roller of Rod Stand
- Thread Carriage W/All Comp
- Thread Tension Device
- Wrap Motor

# "THE PRO-WRAPPER"

FOR THE CUSTOM ROD BUILDER

SHOFF TACKLE CO.  
P.O. Box 2056  
Renton, Wa. 98056



- Self Centering Chuck
- Holds blanks up to 1 1/2" diameter
- Finish and drying motor
- Multi-spool thread transport with tension device
- 3 fully adjustable rod stands with ball bearing wheels
- Foot and dial controlled wrapping motor
- Turn cork grips
- 45 degree indications on flywheel for diamond wraps
- Sectional 8' anodized aluminum base
- Spare parts available

ORDER ON-LINE AT  
[shofftackle.com](http://shofftackle.com)

Web Site: <http://www.shofftackle.com>

E-Mail [shofftackle@comcast.com](mailto:shofftackle@comcast.com)

Phone 425-277-5274

Fax 425-235-0076